



KAN-therm

MAP115MLKAN 1936055008



Serialnumber

HE.19533_A © 02/2021 R&D-2



KAN Sp. z o.o. • 16-001 Białystok-Kleosin • ul. Zdrojowa 51



MAP115MLKAN 1936055008

KAN-therm



Abb. ähnlich / pic. similar
HE.19533_A © 02/2021



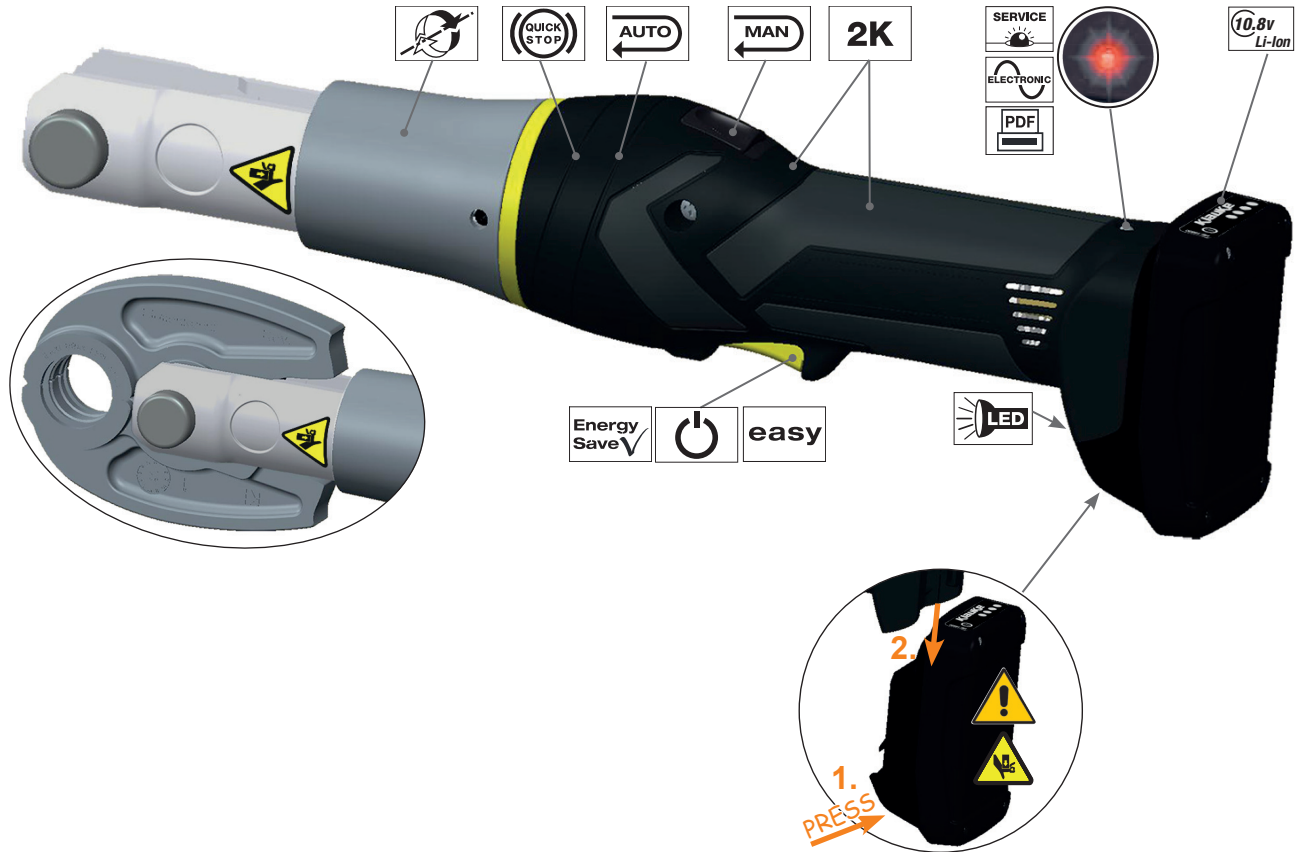

MAP115MLKAN 1936055008

KAN-therm

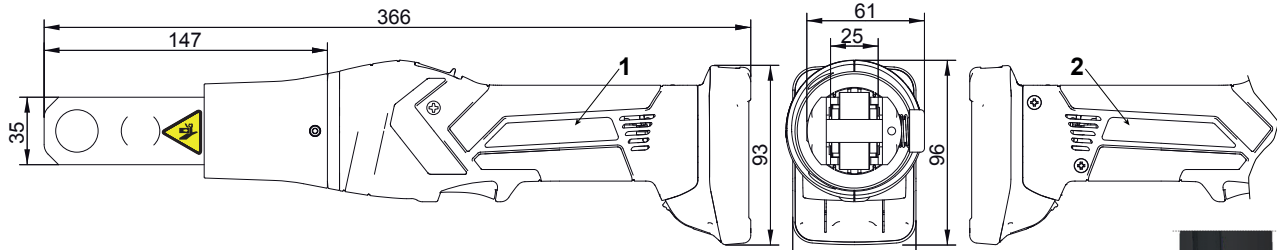

	VIBR
<70dB	<2,5m/s ²
	BIO
+40°C -10°C	
1,6 kg	15 kN



304711
PR
142

Klauke
Auf dem Knapp 46
D-42855
Remscheid

2 x

PRESS

batch# e.g. 304711
datecode e.g. P = 2020; R = April
consecutive# e.g. „142“ = tool # 142

datecode

Year	Code	Month	Code	Month	Code
2018	M	Jan.	N	July	V
2019	N	Feb.	P	Aug.	W
2020	P	Mar.	Q	Sept.	X
2021	Q	Apr.	R	Oct.	Y
2022	R	May	S	Nov.	Z
2023	S	June	T	Dec.	1

ACHTUNG!
Garantisiegel Nr. XXX XXX
Bei Beschädigung Garantieverlust

2 years
Warranty
World wide
Tool Service
Challenge 2023

Abb. ähnlich / pic. similar
HE.19533_A © 02/2021

WORK



SERVICE



DON'T DO



General safety rules



MAP115MLKAN 1936055008

KAN-therm



2 years
Warranty
World wide
Tool
Service

2 years
Warranty
World wide
Tool
Service

ACHTUNG! Bei Beschädigung Garantieversicht
ATTENTION! Warranty seal if broken

Garantiesiegel
Garantieversicht
Warranty seal
if broken



WEEE
2012/19/EU

@ Klauke-WEEE-Abholung@Emerson.com

Klauke ASC
Authorised Service Center

3 years or
10.000 operations

Klauke ASC
Authorised Service Center

OLD
PART
REPLACEMENT
SAFETY
NEW

2 years
Warranty
World wide
Tool
Service

once a year

Klauke ASC
Authorised Service Center

Recommendation
Empfehlung

Abb. ähnlich / pic. similar
HE.19533_A © 02/2021

WORK

SERVICE

DON'T DO

General safety rules



WARNING

Read all safety warnings, instructions, illustrations and specifications provided with this power tool.

Failure to follow all instructions listed below may result in electric shock, fire and/or serious injury.

Save all warnings and instructions for future reference.

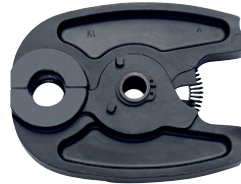

Applications

Stainless steel, steel	max. 22 mm* (28 mm upon request)
Copper, copper alloys	max. 28 mm*
Multi-layer composite pipe	max. 32 mm*
PEX pipe	max. 32 mm*

* These values are system-related
Please contact your system supplier for binding information





MAP115MLKAN 1936055008

KAN-therm



Abb. ähnlich / pic. similar
HE.19533_A © 02/2021

WORK



SERVICE

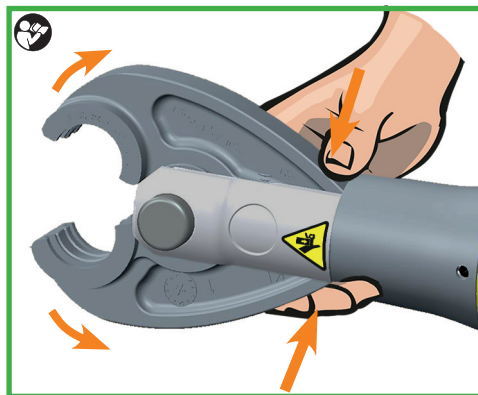
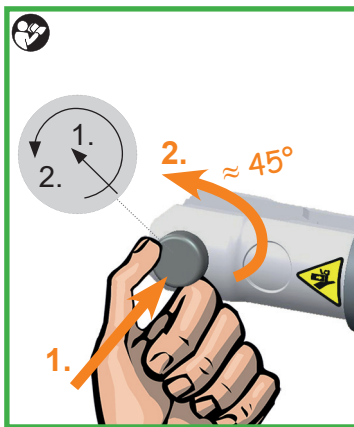

DON'T DO



General safety rules





Abb. ähnlich / pic. similar
HE.19533_A © 02/2021



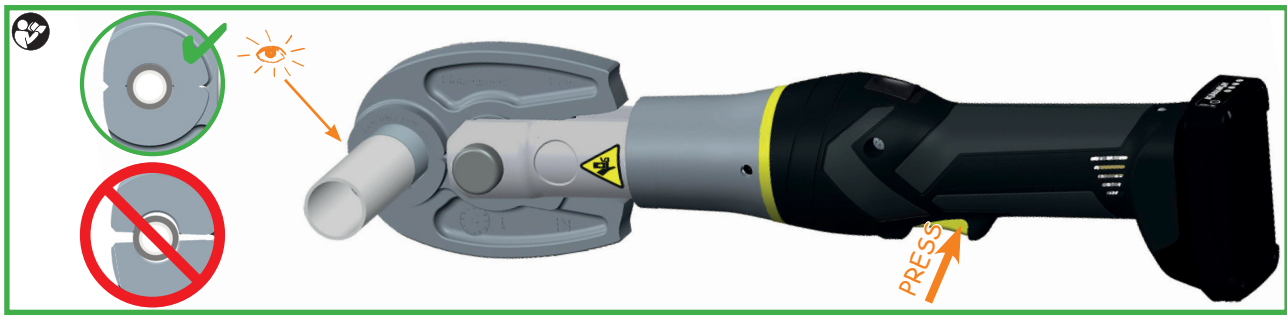
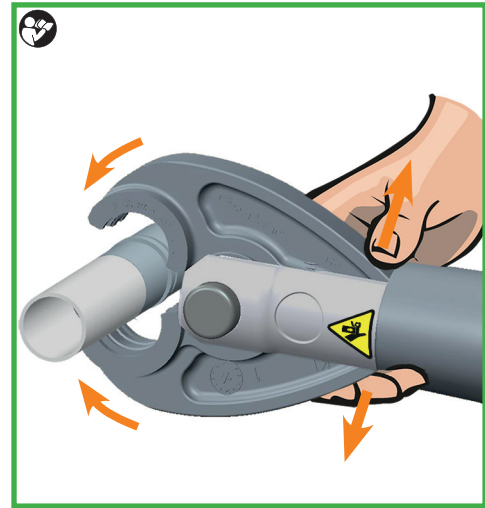
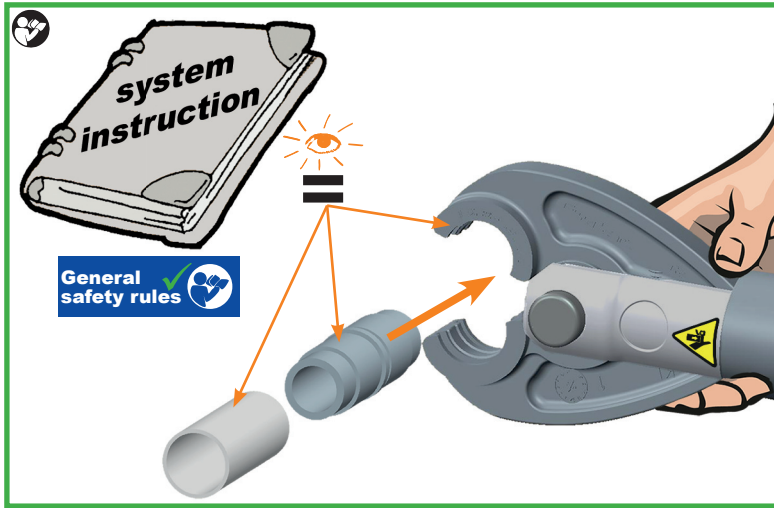

MAP115MLKAN 1936055008

KAN-therm



Abb. ähnlich / pic. similar
HE.19533_A © 02/2021

WORK



SERVICE

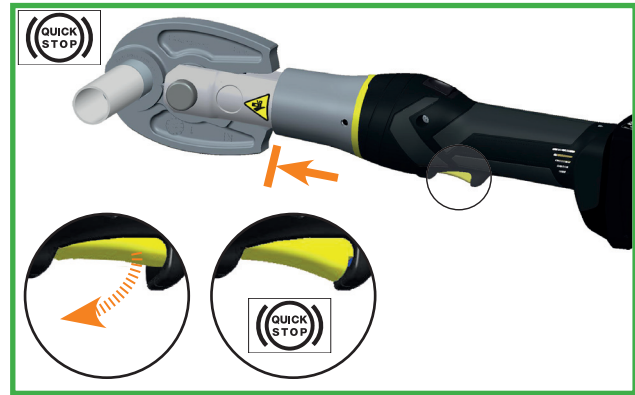
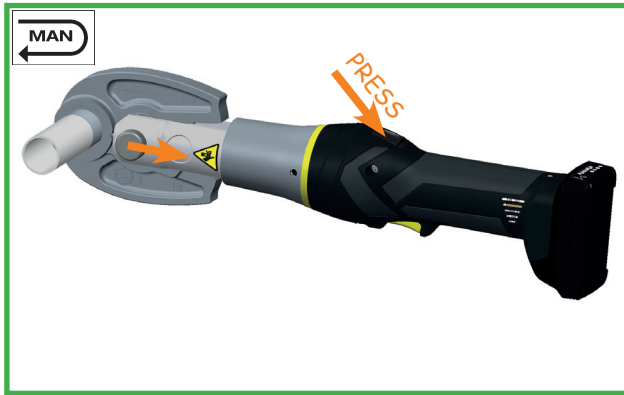
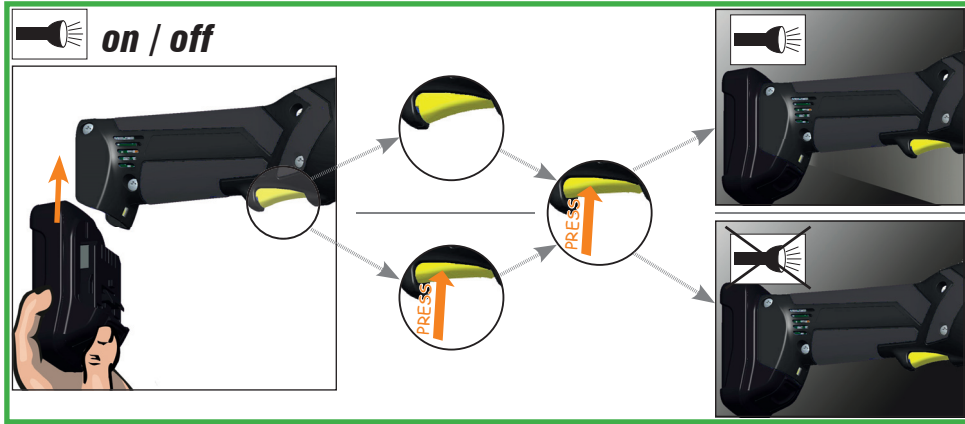

DON'T DO



General safety rules



MAP115MLKAN 1936055008

KAN-therm

Klauke®

LGML1

Li-Ion Charger

Gustav Klauke GmbH
Auf dem Knapp 46
D-42855 Remscheid

Input: 230V 50-60 Hz 35W

Output: 10.8 V 21.6W

Charge current: 2.0 A



Charging:
0° - 40°C

Made in Czech Republic

HE.15563_G

LGML1



RAML1
40 min.

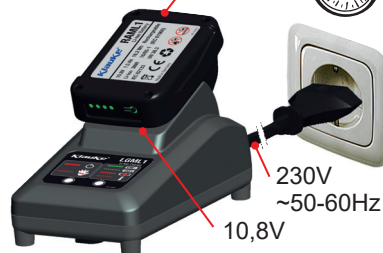

230V
~50-60Hz
10,8V

Klauke®

RAML1

Li-Ion Battery

Gustav Klauke GmbH
Auf dem Knapp 46-D-42855 Remscheid

10.8V 1.5 Ah 16.2 Wh IEC 62133

Li-Ion 31NR 18/65 Rechargeable UN 38.3

☎ 0082226140989

ZU10842-18001
Nanjing ENZO
Industry Co., Ltd.



R - 41154210



Made in China

For use only with LGML1 charger

HE.16023_K



Abb. ähnlich / pic. similar
HE.19533_A © 02/2021





MAP115MLKAN 1936055008

KAN-therm

LGML1

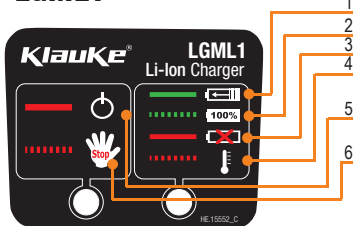

D	GB	F	E
1 Ladeprozess beginnt	Charger is charging	Batterie en charge	Cargando
2 Akku ist vollgeladen	Battery is fully charged	Charge complete	Bateria cargada completamente
3 Akku ist defekt	Battery is defect	Batterie défectueuse	Bateria defectuosa
4 Akku ist zu heiß oder zu kalt	Battery is too hot or too cold	Batterie trop chaude ou trop froide	La batería está demasiado caliente o fría
5 Ladegerät ist am Stromnetz angeschlossen und ladebereit	Charger is connected with the mains socket and ready to charge.	Chargeur branché à la prise de courant prêt à être chargé.	El cargador está conectado a la red y listo para cargar
6 Ladegerät ist defekt	Charger is defect	Chargeur défectueux	Cargador defectuoso
Achtung (1. + 2.) Bitte beachten Sie, dass der Akku aus dem Ladeschacht entnommen werden muß, wenn das Ladegerät nicht am Netz angeschlossen ist. Ansonsten wird der Akku tiefentladen!	Attention (1. + 2.) Please remove the Battery out of the charging slot if the charger is not plugged into the socket. Failing to do so might results in destroying the battery by deep discharge!	Attention (1. + 2.) Sortir la batterie du chargeur si le chargeur n'est pas branché à la prise de courant. Ceci pourrait endommager la batterie avec chute de la charge!	Atención (1. + 2.) Por favor tenga en cuenta de quitar la batería de la base de carga cuando el cargador no esté conectado a la red. De lo contrario la batería sufrirá una descarga intensa.













I	P	NL	PL
1 La carica sta iniziando	O carregador está em carga	laadproces begint	Ładowanie zaczęte
2 La batteria è completamente carica	A bateria está completamente carregada	Accu is vol geladen	Akumulator naładowany w pełni
3 La batteria è difettosa	A bateria está com defeito	Accu is defect	Akumulator jest uszkodzony
4 La batteria è troppo calda o troppo fredda	A bateria está demasiado quente ou fria	Accu is te heet of te koud	Akumulator jest za gorący lub za zimny
5 Il caricabatterie è attaccato alla corrente ed è pronto per essere caricato	O carregador está ligado à corrente e pronto a carregar	lader is aangesloten aan het stromnet en klaar om te laden	Ładowarka jest podłączona do sieci i gotowa do pracy
6 Il caricabatterie è difettoso	O carregador está com defeito	lader is defect	Ładowarka jest uszkodzona
Attenzione: (1. + 2.) Per favore assicurarsi che la batteria venga rimossa dal caricatore, quando il caricabatterie non è attaccato alla corrente. Altrimenti la batteria rischia di scaricarsi completamente	Atenção (1. + 2.) Tenha em atenção que a bateria deve ser retirada do carregador quando não estiver ligado à corrente. Se não o fizer pode resultar na destruição da bateria por descarga intensa!	Opgelet (1.+2.) Aub de accu uit de ladesleuf verwijderen als de lader niet aan het stromnet is aangesloten. Als niet kann het tot een diepontlading van de accu komen	Uwaga (1 + 2) Proszę pamiętać, że akumulator musi być usunięty ze złącza ładowarki w chwili, gdy nie jest ona podłączona do sieci. Inaczej akumulator może ulec głębokiemu rozładowaniu.

RUS	
1 Идет процесс зарядки	4 Аккумулятор очень горячий или холодный
2 Аккумулятор полностью заряжен	5 Зарядное устройство подключено к сети и готово к зарядке
3 Аккумулятор поврежден	6 Зарядное устройство повреждено
Внимание (1 + 2) Обратите внимание, что аккумулятор нужно извлекать из зарядного устройства только если зарядное устройство отключено от сети. В противном случае может произойти полная разрядка аккумулятора.	



MAP115MLKAN 1936055008

KAN-therm

	Wann/When/Quand/Quando/quando/cuándo/ Wanneer/Когда это происходит/Kiedy	Warum/Why/Pourquoi/Porquê/perché/¿por qué?/ Waarom/Причина/Dlaczego
 20 sec	nach Arbeitsvorgang/after working cycle après opération de travail Después del proceso de trabajo dopo il processo di lavoro após o processo de trabalho na bedrijfscyclus после цикла опрессовки po zakończeniu pracy	
 2 x	nach Einsetzen des Akkus/after inserting the battery après mise en place de l'accumulateur Después de insertar la batería dopo l'inserimento della batteria após inserir a bateria na het plaatsen van de accu при установке аккумулятора przy włożeniu akumulatora	Selbsttest/Self check autocontrôle Auto-test Auto-test Autoteste zelftest Проверка инструмента autotest
 20 sec/2Hz	nach Arbeitsvorgang/after working cycle après opération de travail Después del proceso de trabajo após o processo de trabalho na bedrijfscyclus после цикла опрессовки po zakończeniu pracy dopo il processo di lavoro	 
 20 sec/5Hz	während der Übertemperatur/while exceeding the temp. limit pendant surchauffé en caso de temperatura excesiva medan temperaturbegränsningen durante a temperatura excessiva tijdens te hoge temperatuur при высокой температуре внутри корпуса w czasie nadmiernej temperatury	Werkzeug zu heiß/Unit too hot outil surchauffé Herramienta demasiado caliente Utensile troppo caldo ferramenta demasiado quente gereedschap te heet Перегрев инструмента narzędzie za gorące
 20 sec  20 sec/2Hz	nach Arbeitsvorgang/after working cycle après opération de travail Después del proceso de trabajo dopo il processo di lavoro após o processo de trabalho na bedrijfscyclus после цикла опрессовки po zakończeniu pracy	  

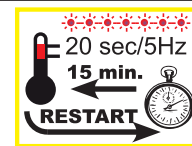

Handgeführtes batteriebetriebenes Crimpwerkzeug Typ MAP115MLKAN Handoperated battery driven crimping tool type MAP115MLKAN

(D) CE -'15 - Konformitätserklärung. Wir erklären in alleiniger Verantwortlichkeit, daß dieses Produkt mit den folgenden Normen oder normativen Dokumenten übereinstimmt:

EN 62841-1, EN ISO 12100, EN ISO 13857, EN 349, EN 28662-1, EN 61000-6-3, EN 61000-6-2, EN 1037 gemäß den Bestimmungen der Richtlinien 2006/42/EU, 2014/30/EU, 2011/65/EU

(GB) CE -'15 - Declaration of conformity. We declare under our sole responsibility that this product is in conformity with the following standards or normative documents:

EN 62841-1, EN ISO 12100, EN ISO 13857, EN 349, EN 28662-1, EN 61000-6-3, EN 61000-6-2, EN 1037 in accordance with the regulations of directives 2006/42/EU, 2014/30/EU, 2011/65/EU

(F) CE -'15 - Déclaration de conformité. Nous déclarons sous notre seule responsabilité que ce produit est en conformité avec les normes ou documents normatifs suivants:

EN 62841-1, EN ISO 12100, EN ISO 13857, EN 349, EN 28662-1, EN 61000-6-3, EN 61000-6-2, EN 1037 conformément aux réglementations des directives 2006/42/EU, 2014/30/EU, 2011/65/EU

(NL) CE -'15 - Konformiteitsverklaring. Wij verklaren er alleen voor verantwoordelijk dat dit produkt voldoet aan de volgende normen of normatieve documenten:

EN 62841-1, EN ISO 12100, EN ISO 13857, EN 349, EN 28662-1, EN 61000-6-3, EN 61000-6-2, EN 1037 overeenkomstig de bepalingen van de richtlijnen 2006/42/EU, 2014/30/EU, 2011/65/EU

(P) CE -'15 - Declaração de conformidade. Declaramos sob nossa exclusiva responsabilidade que este producto cumple as seguintes normas ou documentos normativos:

EN 62841-1, EN ISO 12100, EN ISO 13857, EN 349, EN 28662-1, EN 61000-6-3, EN 61000-6-2, EN 1037 conforme as disposições das directivas 2006/42/EU, 2014/30/EU, 2011/65/EU

(N) CE -'15 - Konformitetserklæring. Vi erklærer på eget ansvarlighet at dette produkt er i overensstemmelse med følgende standarder eller standard-dokumenter:

EN 62841-1, EN ISO 12100, EN ISO 13857, EN 349, EN 28662-1, EN 61000-6-3, EN 61000-6-2, EN 1037 i henhold til bestemmelserne i direktive ne 2006/42/EU, 2014/30/EU, 2011/65/EU

(E) CE -'15 - Declaración de conformidad. Declaramos bajo nuestra sola responsabilidad que este producto está en conformidad con las normas o documentos normativos siguientes:

EN 62841-1, EN ISO 12100, EN ISO 13857, EN 349, EN 28662-1, EN 61000-6-3, EN 61000-6-2, EN 1037 de acuerdo con las regulaciones de las directivas 2006/42/EU, 2014/30/EU, 2011/65/EU

(I) CE -'15 - Dichiarazione di conformità. Dichiariamo sotto la nostra esclusiva responsabilità che questo prodotto è conforme alle seguenti norme e documenti normativi:

EN 62841-1, EN ISO 12100, EN ISO 13857, EN 349, EN 28662-1, EN 61000-6-3, EN 61000-6-2, EN 1037 conformemente alle disposizioni delle direttive 2006/42/EU, 2014/30/EU, 2011/65/EU

(DK) CE -'15 - Konformitetserklæring. Vi erklærer under almindeligt ansvar at dette produkt er i overensstemmelse med følgende normer eller normative dokumenter:

EN 62841-1, EN ISO 12100, EN ISO 13857, EN 349, EN 28662-1, EN 61000-6-3, EN 61000-6-2, EN 1037 i henhold til bestemmelserne i direktiverne 2006/42/EU, 2014/30/EU, 2011/65/EU

(FIN) CE -'15 - Todistus standardinmukaisuudesta. Asiasta vastaavana todistamme läten, että tämä tuote on seuraavien standardien ja standardoimisasiakirjojen vaatimusten mukainen:

EN 62841-1, EN ISO 12100, EN ISO 13857, EN 349, EN 28662-1, EN 61000-6-3, EN 61000-6-2, EN 1037 ja vastaa säädöksiä 2006/42/EU, 2014/30/EU, 2011/65/EU

(PL) CE -'15 - Zgodność z dyrektywami CE. Świadomi odpowiedzialności oświadczamy, że niniejszy produkt jest zgodny z następującymi normami lub dokumentacją normatywną:

EN 62841-1, EN ISO 12100, EN ISO 13857, EN 349, EN 28662-1, EN 61000-6-3, EN 61000-6-2, EN 1037 zgodnie z postanowieniami wytycznych 2006/42/EU, 2014/30/EU, 2011/65/EU

(GR) CE -'15 - ΔΗΛΩΣΗ ΣΥΜΜΟΡΦΩΣΗΣ Με ααληγήηη ηηοδοληθή δηλωοημε οη οη ποροη προηον οημφωηει με ηα παρακαηο ποοηηα και με ηα ηροηηηα ηηο ααηεφροηηαι οηα οηεπηκο εγγρραφα EN 62841-1, EN ISO 12100, EN ISO 13857, EN 349, EN 28662-1, EN 61000-6-3, EN 61000-6-2, EN 1037 οημφωηα με ηοηο κοηοηηομοιοο 2006/42/EU, 2014/30/EU, 2011/65/EU

(H) CE -'15 - Megfelelőségi nyilatkozat. Kéziműködtetésű elektromos kéziszerszámok: Teljes felelősséggel kijelentjük, hogy ezek a termékek a következő szabványokkal és irányelvekkel összhangban vannak: EN 62841-1, EN ISO 12100, EN ISO 13857, EN 349, EN 28662-1, EN 61000-6-3, EN 61000-6-2, EN 1037; és megfelelnek a rendeltetés szerinti 2006/42/EU, 2014/30/EU, 2011/65/EU irányelveknek.

(SK) CE -'15 - Prehlásenie o zhode. Prehlasujeme na vlastnú zodpovednosť, že tieto produkty sú v súlade s nasledovnými normami: EN 62841-1, EN ISO 12100, EN ISO 13857, EN 349, EN 28662-1, EN 61000-6-3, EN 61000-6-2, EN 1037 a v zhode so smernicami 2006/42/EU, 2014/30/EU, 2011/65/EU

(CZ) CE -'15 - Prohlášení o shodě. Prohlasujeme na vlastní zodpovednost, že tyto produkty splňují následující normy nebo normativní listiny:

EN 62841-1, EN ISO 12100, EN ISO 13857, EN 349, EN 28662-1, EN 61000-6-3, EN 61000-6-2, EN 1037; Ve shodě se smernicemi 2006/42/EU, 2014/30/EU, 2011/65/EU

(S) CE -'15 - Konformitetsdeklaration. Vi förklarar på eget ansvar att denna produkt överensstämmer med följande normer eller normativa dokument:

EN 62841-1, EN ISO 12100, EN ISO 13857, EN 349, EN 28662-1, EN 61000-6-3, EN 61000-6-2, EN 1037 enligt bestämmelserna i direktiverna 2006/42/EU, 2014/30/EU, 2011/65/EU

(RO) CE -'15 - Declarație de conformitate. Noi declarăm pe propria răspundere că acest produs este în conformitate cu următoarele norme și documente normative:

EN 62841-1, EN ISO 12100, EN ISO 13857, EN 349, EN 28662-1, EN 61000-6-3, EN 61000-6-2, EN 1037; potrivit dispozițiilor directivelor 2006/42/EU, 2014/30/EU, 2011/65/EU

Remscheid, den 05.03.2015

CE

Dipl.-Ing. Joh.-Christoph Schütz, CE-Beauftragter